

S. H. JONES.
TIDE MOTOR.

(Application filed Feb. 1, 1898.)

(No Model.)

3 Sheets—Sheet 1.

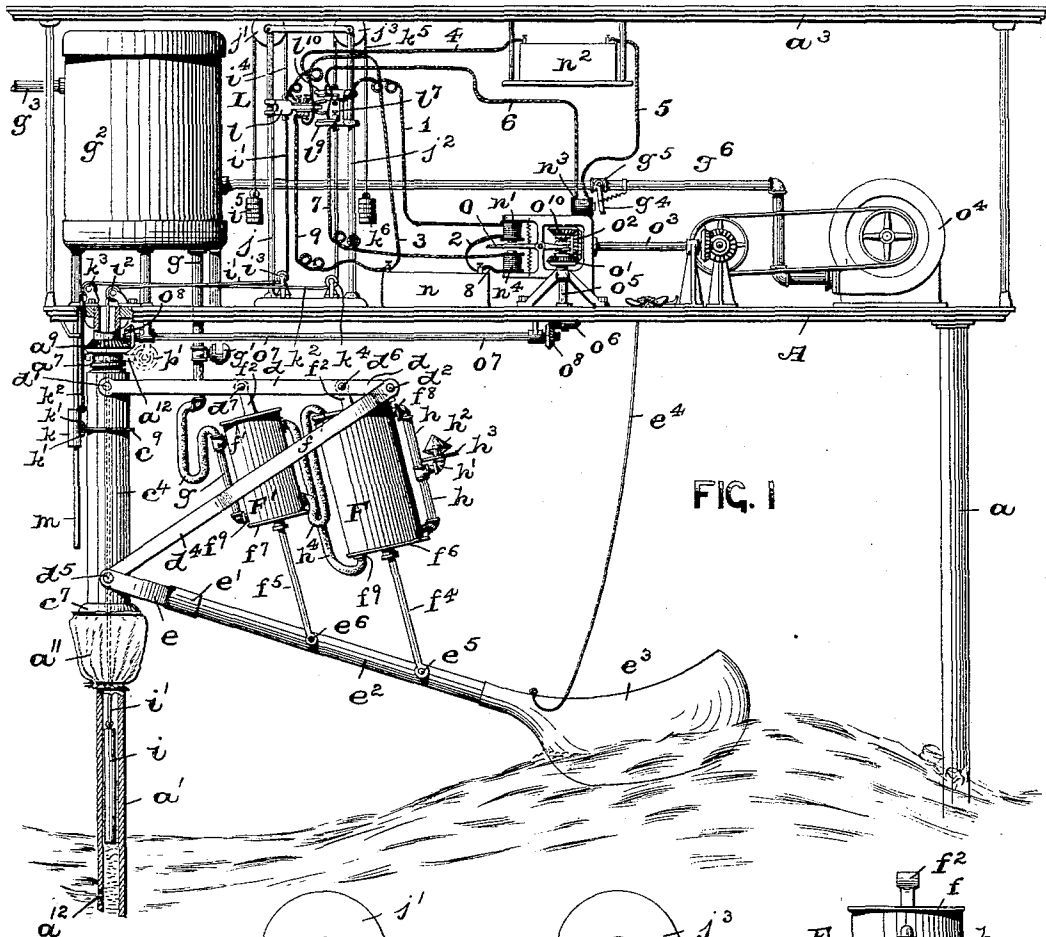

FIG. 1

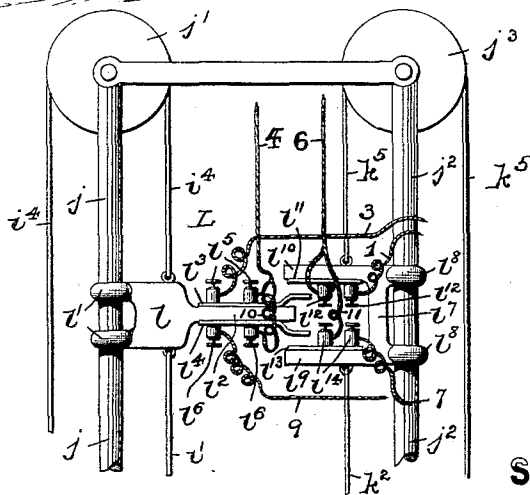

FIG. 2

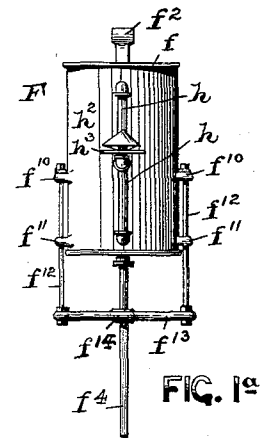

FIG. 1a

WITNESSES:

Marcy J. Ormsdell.
Wm. H. Campfield Jr.

INVENTOR:

SAMUEL H. JONES,

BY
Fred C. Fraentzel,
ATTORNEY

No. 616,467.

Patented Dec. 27, 1898.

S. H. JONES.
TIDE MOTOR.

(Application filed Feb. 1, 1898.)

(No Model.)

3 Sheets—Sheet 2.

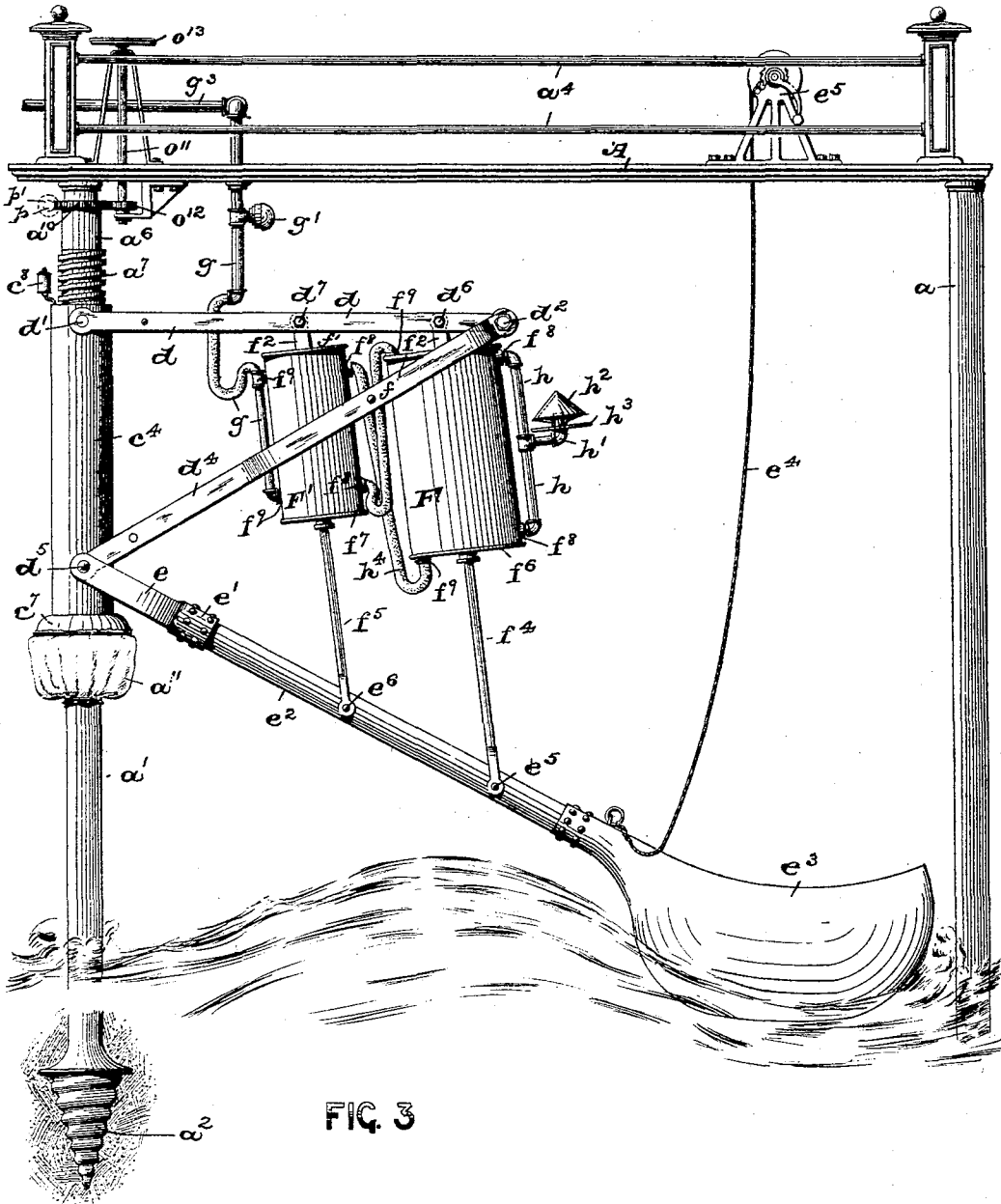

FIG. 3

WITNESSES:

Marcy J. Trusdell

Wm. O. Campfield, Jr.

INVENTOR:

SAMUEL H. JONES,

BY

Fred C. Graentzel,

ATTORNEY

S. H. JONES.

TIDE MOTOR.

(Application filed Feb. 1, 1898.)

(No Model.)

3 Sheets--Sheet 3.

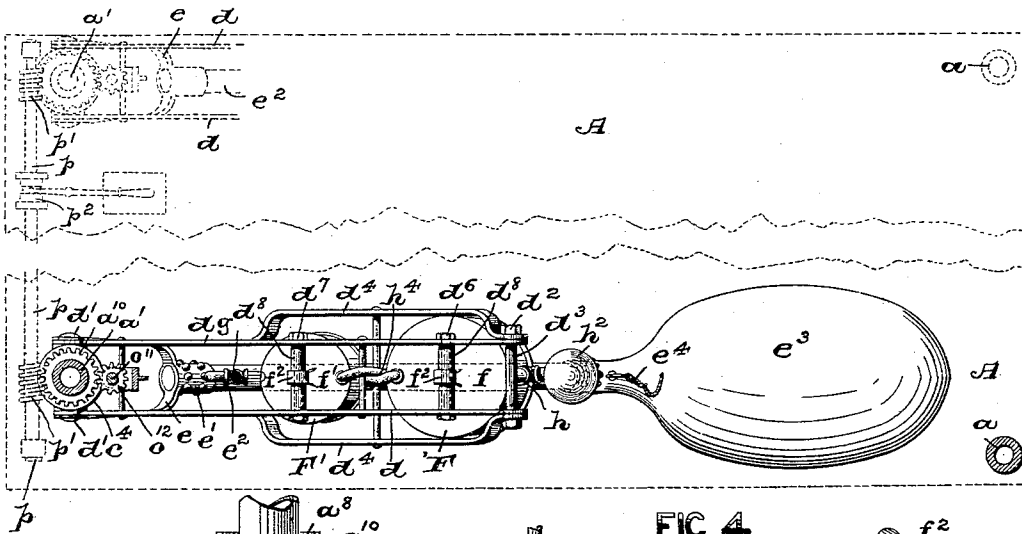

FIG. 4

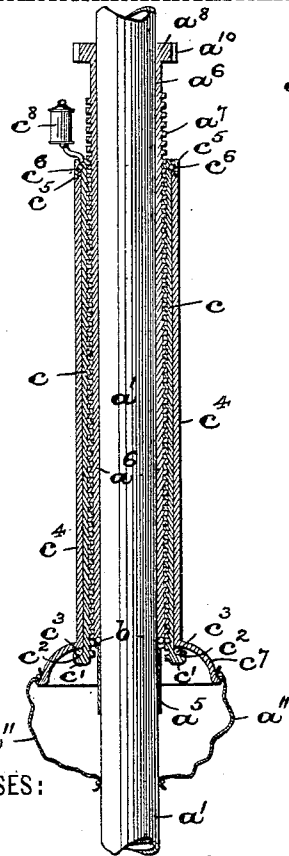

FIG. 5

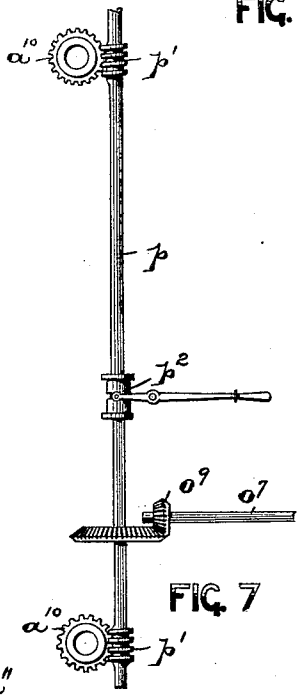

FIG. 7

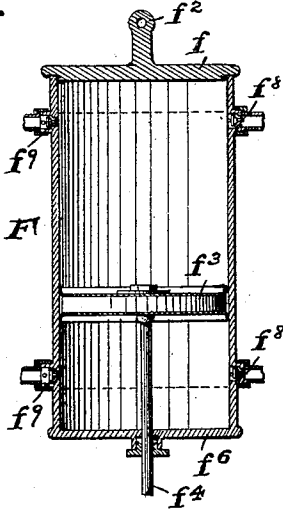

FIG. 6

WITNESSES:

Marcy J. Trusdell
Wm. H. Campfield, Jr.

INVENTOR:
SAMUEL H. JONES,
BY
Fred C. Graentzel,
ATTORNEY

UNITED STATES PATENT OFFICE.

SAMUEL H. JONES, OF NEWARK, NEW JERSEY.

TIDE-MOTOR.

SPECIFICATION forming part of Letters Patent No. 616,467, dated December 27, 1898.

Application filed February 1, 1898. Serial No. 668,732. (No model.)

To all whom it may concern:

Be it known that I, SAMUEL H. JONES, a citizen of the United States, residing at Newark, in the county of Essex and State of New Jersey, have invented certain new and useful Improvements in Wave-Power-Storing Apparatus; and I do hereby declare the following to be a full, clear, and exact description of the invention, such as will enable others skilled in the art to which it appertains to make and use the same, reference being had to the accompanying drawings, and to letters and figures of reference marked thereon, which form a part of this specification.

The present invention relates generally to improvements in that class of apparatus for storing wave-power, and more especially to a novel arrangement of mechanism for applying the power of the waves of the ocean to a pump or pumps connected with and operated by a float, which compresses the air and which is conducted by pipes to the shore and there directly applied to the propulsion of useful machinery of the various kinds.

My invention therefore has for its various objects, first, to provide a novel construction of wave-motor comprising a float hinged to a pier and connected therewith to allow the float to rise and fall with each wave, and also being capable of a swimming motion about the pier, and a series of double-acting and compression pumps operatively connected with said pier and actuated by the float, the pumps being arranged in multiple and one receiving air from the other to obtain an increased compression of air; second, by such arrangement of compression-pumps connected in series or multiple with each other to obtain power with greater economy than heretofore, for without such arrangement of the pumps the greater part of the power of the waves would be lost, since it would require a full stroke of a single-acting pump to fully compress the air so as to open the valve into the receiving-pipe, and such stroke could only be made when a full-sized wave lifts the float. On the other hand, however, with my novel arrangement of double-acting compression-pumps in series or multiple every motion of the waves is sufficient to operate the movable parts of the mechanism; third, to provide an arrangement and construction of double-act-

ing compression-pumps, whereby every stroke of the piston is utilized, whether alternately or in the same direction of the previous stroke 55 irrespective of the wave action on the float, and each piston is operative, whether oscillating in the middle or at either end of the pump-cylinders; fourth, to provide a simple and operative as well as a strong construction 60 of apparatus, in which the parts are intended to secure strength to resist the great and uncertain force of the waves; fifth, to so arrange certain parts of the mechanism as to protect them from the wave action, consequent 65 spray, and the corrosive elements of sea-water, also from the injurious effect of sudden jars and shocks which is obviated by the fact that the power is transmitted through an elastic medium, as the air, and by further 70 providing an air-cushion at the ends of one or more of the pumps, so that the piston cannot be forcibly driven against the pump-heads; sixth, to provide a guide mechanism for the pumps to prevent their being forced out of 75 alinement whenever the piston reaches the lower end of the pump and to prevent unnecessary wear and jamming of parts; seventh, to provide a means for raising and lowering the position of the pump-supporting structure 80 connected with the pier to suit the height of the water due to the tide-waters; eighth, to provide an automatic arrangement attached to a tidal float which maintains the several parts of the apparatus at the proper height 85 and may operate several wave-motors in multiple, and to furnish power by means of an electric regulator controlled by said tidal float and intermediate gear mechanism and shafting, whereby an unlimited number of 90 wave-motors in the same system can be maintained at the proper height relative to level of the sea and according to the varying tides; and, finally, my invention has for its principal object to improve the general construction 95 of wave-motors, the several parts in my apparatus being arranged to perform their work in the most effective and reliable and most economical manner.

With these several ends in view my invention 100 consists in the apparatus to be hereinafter fully described, as well as in the general arrangements and combinations of the several mechanism, the purposes of which

have been set forth in the above, as well as in the several details of the construction of the several parts of mechanism, taken singly or collectively, all of which are to be described more in detail in the accompanying specification, and then finally embodied in the clauses of the claim hereto appended.

The invention is clearly illustrated in the accompanying drawings, in which—

10 Figure 1 is a side elevation of one form of apparatus for storing wave-power embodying the leading features of my present invention. Fig. 1^a is a detail view of one of the air-compressing pumps to be used in connection with the apparatus; and Fig. 2 is a detail view of an electric regulator, on an enlarged scale, illustrated in connection with the apparatus represented in Fig. 1 and controlled by a tidal float, also shown in said Fig. 1. Fig. 3 is a side elevation of a wave-motor made according to my invention, but of a slightly-modified form of construction; and Fig. 4 is a plan view of the same, said view also illustrating in dotted outline one means of operatively connecting two or more of the motors in series. Fig. 5 is a portion of the pier and a movable collar or sleeve thereon represented in vertical section, illustrating one means of pivotally and rotatably connecting the float with the pier. Fig. 6 is a vertical section of one of the air-compressing pumps, and Fig. 7 is a detail view of a modified form of mechanism for raising and lowering the rotatable sleeves or collars on the several piers.

35 Similar letters and figures of reference are employed in all of the above-described views to indicate corresponding parts.

In said drawings, A indicates a suitable platform, bridge, or the like supported in any well-known manner upon suitable piers or posts *a* at one end and at the other upon one, two, or any other desirable number of hollow posts or piers *a'*, said pier or piers *a'* forming an essential part of the apparatus for collecting and storing the wave-power. Each post or pier may be provided with a suitable anchor, as *a²*, whereby it is firmly planted in the bottom of the sea at the desired point and at a suitable distance from the shore. The mechanism on the platform or bridge A may be protected from the elements by a suitable shed or roof, as *a³*, as clearly indicated in Fig. 1, and a suitable railing *a⁴* may be placed upon the bridge or platform, as illustrated in Fig. 3, said railing being omitted in Fig. 1 in order that the mechanism represented in said Fig. 1 may not be obscured. As indicated more especially in Fig. 5, each pier or piers *a'* is provided with a fixed collar *a⁵*, which is firmly secured to the pier in the desired position and in any of the usual manners. Resting upon ball-bearings *b* on said collar *a⁵* and rotatably arranged thereon and on said pier *a'* is a long sleeve *a⁶*, which is provided with an external screw-thread *a⁷* and at the top with an annular part *a⁸*, formed with a bevel-gear *a⁹*, as

illustrated in Fig. 1, or with the ordinary gear-teeth *a¹⁰*, as illustrated in Figs. 4 and 5, the purpose of which will be more fully described hereinafter. Upon the screw-thread *a⁷* of the long sleeve *a⁶* I have placed a second sleeve *c*, having an internal screw-thread in engagement with the screw-thread *a⁷*, said sleeve *c* having a reciprocatory but non-rotative motion on said sleeve *a⁶*. At the bottom said sleeve *c* is provided with a bearing portion, as *c'*, having an annular groove or channel *c²* with antifriction balls or rollers *c³* therein. Rotatively arranged on said balls or rollers and on said sleeve *c*, but incapable of a reciprocatory motion upon said sleeve *c*, is a third and outer sleeve *c⁴*, which is held in place at the top by a screw-cap *c⁵*, rotatably connected with said sleeve *c* by the ball-bearings *c⁶*, substantially as illustrated. The lower end of said outer sleeve *c⁴* is preferably made cup-shaped, as at *c⁷*, and has attached thereto a suitable and flexible apron *a¹¹*, arranged at the bottom around the pier *a'* to protect the several parts of the bearing from contact with the sea-water. Said apron is arranged about the pier *a'* in such a manner that it will not interfere with the rotary motion of the several sleeves, but still protects said parts from contact with the spray when the sea is very rough. A suitable lubricator *c⁸* may be placed at or near the top of said sleeves to constantly supply them with oil or other suitable lubricating material and whereby a free motion of said parts will be readily maintained.

As clearly illustrated in Figs. 1, 3, and 4, immovably secured on opposite sides of the outer sleeve *c⁴* and upon suitable pins or bolts *d'* are a pair of arms *d*, connected at their free ends by a bolt *d³* and a collar or tube *d³* on said bolt *d³* between said ends to retain said arms *d* at their proper distance apart from one another. Connected with said bolts *d²* are a pair of downwardly-extending braces *d⁴*, having their lower ends arranged on and permanently secured to the opposite sides of the sleeve *c⁴* by means of suitable pins or bolts *d⁵*, whereby the arms *d* are thoroughly braced to withstand the shocks and strains to which the apparatus is subjected and form a desirable support for one, two, or more air-compressing pumps. Pivoted to said pins or bolts *d⁵* on said sleeve *c⁴* is a suitable yoke *e*, having a socket *e'*, in which is secured in any well-known manner a bar or arm *e²*, preferably made hollow and of metal, and has at its lower end a hollow body *e³*, made of metal and forming a float, preferably in the form of the body of a swan, duck, or other aquatic bird, whereby said float will easily ride the waves and will be capable of an up-and-down motion as well as a lateral swimming motion, according to the direction of the impact of the waves against said float. A rope or other suitable flexible connection *e⁴* is preferably attached to said float *e³* and the bridge or platform A, which hangs slack to

permit of a limited lateral swimming motion of said float and to thereby break the force of impact against the float when a wave strikes it on the side. Between said arms d are bolts or pins d^6 and d^7 , each of which is provided with collars d^8 , as will be seen from Fig. 4. Pivotaly arranged on the bolts d^6 and d^7 and centrally between the collars d^8 thereon are the perforated lugs f^2 of the cylinder-heads f and f' of the respective air-compressing pumps F and F' , respectively. Each pump is provided with a piston f^3 and the respective piston-rods f^4 and f^5 , working through stuffing-boxes in the cylinder-heads f^6 and f^7 , respectively, and are provided with air-inlet valves f^8 and air-outlet valves f^9 , substantially as illustrated in Fig. 6. As indicated in Figs. 1 and 3, the lower ends of the piston-rods f^4 and f^5 are pivotaly connected with the respective pins or bolts e^5 and e^6 on the bar or arm e^2 , connected with the float e^3 . Thus it will be evident that as the float e^3 rises and falls with the motion of the sea the piston-rods will cause their pistons to reciprocate back and forth in their cylinders, the latter receiving an oscillatory motion owing to their pivotal arrangement, which prevents the binding of the pistons within the cylinders and any consequent inoperativeness of the same. From an inspection of the several drawings it will be seen that each cylinder is double acting—that is, it will pump and compress the air on the forward as well as upon the return stroke of its piston, and air will be pumped into and out of the cylinder with the least motion of the float e^3 . The air-compressing pumps are preferably arranged in series and multiple, the first communicating with the second and the second with the third, and so on to the last pump, which has an outlet-pipe g , in which there may be a safety-valve g^1 , said pipe g being connected with an air-receiver g^2 on the bridge or platform A , as in Fig. 1, or with a pipe g^3 , as in Fig. 3, which leads to a similar tank on shore, from which the compressed air can be withdrawn for further use.

The pumps, which, as has been stated, are hinged to the supporting-arms d , and which arms by being secured to the sleeve c^1 on the pier a' are capable of a limited rotary movement in conjunction with the float e^3 and its parts, move freely in a vertical plane beneath said supports d , said pumps being so arranged in the series that the first is nearest the float e^3 and receives the air freely from the outside through a receiving-pipe h , in which there is an inlet h^1 , having its opening protected by a hood h^2 and a shield h^3 to prevent any admission of rain and spray into said pipe h . The valves in the first pump acting in the usual manner and the pump being double acting, the air is delivered under pressure from said pump through flexible ducts or pipes h^4 into the second pump, which having its piston likewise in operation and its valves acting in the same manner as those

of the first pump, delivers the same air under higher pressure into a third pump, and so on to the end of the series of pumps into the receiving-pipe g under increased pressure. For the sake of illustration and simplicity of construction I have shown but two pumps in series in connection with the apparatus; but it will be clearly evident that any desirable and practical number may be employed, all of which are connected with each other in the manner just set forth. It will thus be clearly evident that by my novel arrangement of the air-compression pumps in series or multiple I derive the greatest power with greatest economy, for without this arrangement of the pumps the greatest part of the power of the waves will be lost, since with one pump it would require a full stroke to fully compress the air so as to open the valve into the receiving-pipe, and such stroke could only be made when the float e^3 rides over a full-sized wave. Furthermore, the inlet-valves f^8 , as well as the outlet-valves f^9 , may be placed as indicated more especially in Fig. 6, whereby when the piston on its up or down stroke passes beyond the said valve-openings an air-cushion will be formed between the face of the piston and the inner surface of the upper or lower cylinder-head of the pump, according at which end of the cylinder the said piston happens to be. As an extra precaution to retain the piston-rods of the pumps in proper working alinement and prevent jamming or undue wear of the piston, &c., the cylinder of each pump may be provided with suitable guide-eyes f^{10} and f^{11} , in which I have arranged certain guide-rods f^{12} , connected with a cross head or bar f^{13} , having a centrally-placed guide portion f^4 , through which the piston-rod works, all of which will be clearly evident from an inspection of Fig. 1^a.

As has been previously mentioned, the float e^3 is connected with the bridge or platform A by a suitable flexible connection e^4 , which limits the lateral swimming motion of said float. Said rope, as will be seen from Fig. 3, may be connected with a windlass e^5 upon the bridge or platform, whereby in severe storms the float e^3 and the parts immediately connected therewith can be raised out of harm's way with the rough sea, and when the motors are operated in a large number the floats most exposed to storm action may be raised without decreasing to any great extent the united power of the whole system, since because wave action is so much more powerful during storms than at other times those motors left in use will give all the power required. In such places where there is a periodical rise and fall of the height of the water due to the tides or sudden rises due to storms it is necessary that the movable parts of the apparatus or motor should always adapt themselves to the height of the water-level.

In Fig. 1 I have illustrated one form of mechanism for automatically causing the ro-

tatable parts of the sleeve on the pier a' , to which the float e^3 is hinged, to operate and raise or lower the sleeve to suit the height required. The details of the construction of said raising and lowering mechanism are as follows: The said hollow pier or post a' is provided below the lowest water-mark with one or more perforations a^{12} , so as to admit the sea-water into said post. Floating upon the water in said post is a tide-float i , which has attached thereto a rope or other suitable flexible connection i' . Said rope or connection i' passes up through the hollow post or pier a' and through an opening in the bridge or platform A over a pulley i^2 and pulley i^3 and is attached to a contact-piece l of a suitable electrical regulator L. Said contact-piece has eyes or loops l' , whereby it is slidably arranged on an upright or post j , having a grooved wheel j' at or near the top. A second rope or flexible connection i^4 is attached to the top of said contact-piece l , and this rope or connection i^4 passes over said pulley-wheel j' and has a counterbalance i^5 on its free end. It will thus be seen that as the float i is moved up or down in the post or pier a' said contact-piece l , by the combined action of the balance i^5 and said float i , will receive a corresponding motion upon said upright j . Said contact-piece l , which is made of a non-conducting material, is provided with an arm l^2 , having on opposite sides thereof the electric contact plates or pieces l^3 and l^4 , with binding-posts l^5 on said plate l^3 and binding-post l^6 on said plate l^4 . On an upright j^2 , having a grooved pulley-wheel j^3 , is a slidably-arranged pole-piece l^7 of said regulator L, said piece l^7 having perforated loops or eyes l^8 arranged on said upright or post j^2 for the purposes stated. Slidably arranged on a rod m , extending downwardly from the bridge or platform A in close juxtaposition to said post a' , is a weight k , having a couple of lugs k' , which extend slightly above and below a suitable annular projection c^9 on the sleeve c^4 . A rope or flexible connection k^2 , attached to said weight k , passes over pulley-wheels k^3 and k^4 on the bridge or platform A and is attached to an arm l^9 on said pole-piece l^7 . Attached to a second arm l^{10} on said pole-piece l^7 is a rope or flexible connection k^5 , which passes over the pulley-wheel j^3 and has attached to its free end a weight or counterbalance k^6 . The several parts l^7 , l^8 , l^9 , and l^{10} are all made of a non-conducting material; but on said arm l^{10} is an electric contact-plate l^{11} , provided with the binding-posts l^{12} , while said arm l^9 has a similar contact-plate l^{13} and the binding-posts l^{14} . Now as soon as the float i within the pier a' rises with the tide the weight i^5 causes the contact-piece l^8 of the arm l^2 of the device l to make contact with the plate l^{11} on the arm l^{10} of the pole-piece l^7 . Immediately an electric circuit is established through a battery n , circuit-wires 1, 2, and 3, and an electromagnet n' in said wires 1 and 2, which attracts a clutch-arm c

and throws a bevel-gear o' in operative mesh with a bevel-gear o^2 on a shaft o^3 , connected with a suitable air-engine o^4 for operating said shaft o^3 . At the same time that contact is made between the parts l^8 and l^{11} of the device L an electric circuit is established by means of a battery n^2 , through circuit-wires 4, 5, and 6, and an electromagnet n^3 in said wires 5 and 6. Said magnet n^3 as soon as it becomes energized will attract a lever g^4 , working a valve g^5 in a pipe g^6 , connected with the air-tank g^2 , and the air-engine o^4 is set in operation, which causes the operation of the shaft o^3 , and through the bevel-gears o^2 and o' that of a shaft o^5 , which by means of the bevel-gearing o^6 will actuate a shaft o^7 , having a bevel-gear o^8 in operative mesh with the bevel-gear o^9 on the sleeve a^6 , hereinabove mentioned. The miter or bevel gear o^9 thus set in operation causes the sleeve a^6 on the pier a' to rotate on said pier, whereby the sleeve c and with it the sleeve c^4 will travel upward and will maintain from time to time the fulcrumal point of the bar e^3 of the float e^3 and the support for the compression-pumps at the proper height above the level of the sea.

From an inspection of Fig. 1 it will be evident that said mechanism for operating the sleeve a^6 will cause the sleeve c and its outer sleeve c^4 to travel much faster than the rise and fall of the tide-water. In order that these parts of the mechanism may work properly and in relation to the rise and fall of the tide-water as soon as the sleeve c^4 moves upward, the annular shoulder c^9 on said sleeve will soon be brought in engagement with the upper lug or projection k' on the weight k , thus sliding said weight k upwardly on its rod m , whereby the weight k^6 , connected with the rope or connection k^5 , causes the pole-piece l^7 to slide upwardly on the upright j^2 , and the two contact-pieces l^3 and l^{11} will at once break electrical contact, as will be understood, whereby the electrical circuit through the wires 1, 2, and 3 and battery n as well as the electrical circuit through the wires 4, 5, and 6 and battery n^2 are also broken, and the spring-actuated clutch-arm o and spring-actuated valve-lever g^4 being both released at the same time will assume their normally inoperative positions. (Indicated in said Fig. 1.) By this operation the valve g^5 closes, shuts off the air, the engine o^4 is stopped, and the bevel-gears o' and o^2 are thrown out of their operative engagement. The several shafts and the sleeves on the pier a' will then remain at rest, with the pumps F and F' and the several supporting parts thereof, as well as the fulcrumal arm or bar e^2 , brought to the proper height above the level of the water. These parts will then remain in their relative positions above the level of the sea until the float i is again raised within said hollow pier a' , whereby the clutch mechanism, the valve g^5 , and air-engine o^4 again cause the upward movement of the

movable parts on the pier a' to bring the pumps, their support, and the bar e^2 in proper height above the level of the sea, the weights k and k^6 acting to shut off the power at the proper time. Thus it will be seen that all the mechanism acts automatically and intermittently according to the rising tide. This intermittent action of the mechanism is kept up until the tide falls, when the float i will cause the contact-plate l^4 on the arm l^2 of the device l to make electrical contact with the plate l^{13} on the arm l^9 of the pole-piece l^7 . An electric circuit is now established through the battery n and the circuit-wires 7, 8, and 9 and an electromagnet n^4 in said wires 7 and 8. The now energized magnet n^4 will attract the clutch-arm o and throw another bevel-gear o^{10} on the shaft o^5 in operative mesh with the bevel-gear o^2 on the shaft o^3 . At the same time the plates l^4 and l^{13} through the wires 10 and 11, connected with the circuit-wires 4 and 6, (see Fig. 2,) will establish an electric circuit through the battery n^2 to energize the electromagnet n^3 . The valve-lever g^4 is attracted, the valve g^5 again opened, and the air-engine o^4 started. Owing to the arrangement of the bevel-gear o^{10} the revolutions of shaft o^5 and shaft o^7 are now reversed, which causes a reversed rotary motion of the sleeve a^6 on its pier or post a' and the downward travel of the sleeves c and c^4 on the screw-thread of the sleeve a^6 . In this manner the pumps and parts connected therewith are once more maintained at the proper height above the level of the sea. When the annular shoulder c^9 on the sleeve c^4 comes in contact with the lower projection or lug k' on the weight k , the arm l^9 of the pole-piece l^7 is drawn downwardly, thereby breaking the electrical contact between the parts l^{13} , which causes the normally inoperative positions of the clutch mechanism and the valve-lever g^4 to again close said valve g^5 and stop the engine o^4 . The several parts of the various mechanism thus remain in their inoperative positions, with the pumps working at the proper height above the level of the sea, until the slowly-descending tide-float i again causes the operative engagement of the gears o^{10} and o^2 and the propulsion of the engine o^4 in the manner just set forth to once more operate the sleeves connected with the pier a' and still further lower the support for the pumps and bring the latter and the bar e^2 in their proper relation to the level water. No matter in which direction these several parts of mechanism are caused to revolve to either raise or lower the sleeves c and c^4 on the sleeve a^6 , connected with the pier a' , the action is always intermittent and so timed that the regulating or controlling mechanism will coact with the slowly rising or falling tide, which causes the proper positions of the pumps and connecting parts above the sea-level and their working in the most advantageous and economical manner.

In Fig. 3 I have illustrated another means

for raising or lowering the sleeves c and c^4 on the sleeve a^6 on said pier a' to bring the pumps and connecting parts in their proper heights above the sea-level. In this construction I have arranged in a suitable frame on the bridge or platform A a vertical shaft o^{11} , provided with a hand-wheel o^{13} at the top and a pinion o^{12} at the bottom, which meshes with the gear-teeth a^{10} on the annular flange a^8 , connected with the sleeve a^6 on said pier a' . Thus it will be evident from an inspection of said Fig. 3 that by operating the shaft o^{11} either to the right or left the sleeve a^6 can be likewise turned and the sleeves c and c^4 moved up or down on said sleeve a^6 , whereby the pumps can be located at the desired heights from time to time as may become necessarily due to the rising and falling tides.

From an inspection of Fig. 4 it will be seen that any number of the hereinabove-described wave motors or apparatus may be arranged in series and the various sleeves on the piers a' for maintaining the pumps and the connecting mechanism at their proper heights above the level of the water may be connected in series by a shaft p , having worms p' thereon, which are in operative mesh with the gear-teeth a^{10} , as indicated in the construction in Fig. 3, or with an extra gear-wheel a^{12} on the sleeve a^6 , as indicated in dotted outline in Fig. 1. It will be evident that when the sleeve a^6 on one pier a' is actuated by the tide-float i and the mechanism connected with the air-engine o^4 or by the vertical shaft o^{11} and hand-wheel o^{13} said shaft p is actuated, and the worm p' at the other end will cause the rising and lowering of the proper sleeves on the next pier a' , and so on on all piers thus connected with the operating mechanism of the first pier. A suitable clutch mechanism, as p^2 , may be placed in the shaft p , whereby one or all of the piers and their wave-power-storing mechanism can be disconnected from operative engagement with the first pier. As shown in Fig. 7, the shaft o^7 and its bevel-gear o^9 , which are operated by the air-engine and intermediate mechanism in the manner previously described, may be geared directly with a bevel-gear p^3 on the shaft p in lieu of the manner of connection illustrated in said Figs. 1, 3, and 4.

From the above description it will be clearly understood that I do not limit my invention to any special number of air-compressing pumps nor to any special number of piers a' and the complete wave-power-storing apparatus connected therewith, nor to any special number or kinds of apparatus for regulating and controlling the heights of the pumps and connecting parts above the sea-level, nor to any special construction, number, and kinds of engines for operating the several gear mechanism and shafts connected therewith.

I am fully aware that many changes may be made in the several arrangements and combinations of the mechanism, as well as in the details of the construction of the parts thereof,

without departing from the scope of my present invention. Hence I do not limit my invention to the exact arrangements and combinations of the mechanism as described in the previous specification and as illustrated in the accompanying drawings nor to the exact details of the construction of any of the parts thereof.

Having thus described my invention, what I claim is—

1. In a wave-power-storing apparatus, the combination, with a pier, of a float hinged to said pier, a support on said pier, and a series of air-compressing pumps mounted in said support, and in multiple with each other, whereby one pump forces air into the next pump, and said pumps having piston-rods operatively connected with said float, substantially as and for the purposes set forth.

2. In a wave-power-storing apparatus, the combination, with a pier, of a float hinged to said pier, and having a lateral swimming motion, a laterally-movable support on said pier, and an air-compressing pump mounted in said support, said pump having its piston-rod operatively connected with said float, substantially as and for the purposes set forth.

3. In a wave-power-storing apparatus, the combination, with a pier, of a float hinged to said pier, and having a lateral swimming motion, a laterally-movable support on said pier, and a series of air-compressing pumps mounted in said support, and in multiple with each other, whereby one pump forces air into the next pump, and said pumps having piston-rods operatively connected with said float, substantially as and for the purposes set forth.

4. In a wave-power-storing apparatus, the combination, with a pier and a rotatable collar or sleeve on said pier, of a float hinged to said sleeve, a support fixed to said sleeve, and an air-compressing pump mounted in said support, said pump having its piston-rod operatively connected with said float, substantially as and for the purposes set forth.

5. In a wave-power-storing apparatus, the combination, with a pier, and a rotatable collar or sleeve on said pier, of a float hinged to said sleeve, a support fixed to said sleeve, and a series of air-compressing pumps mounted in said support, and in multiple with each other, whereby one pump forces air into the next pump, said pumps having piston-rods operatively connected with said float, substantially as and for the purposes set forth.

6. In a wave-power-storing apparatus, the combination, with a pier and rotatable and vertically-movable sleeve or collar on said pier, of a float hinged to said sleeve, a support fixed to said sleeve and an air-compressing pump mounted in said support, said pump having its piston-rod operatively connected with said float, substantially as and for the purposes set forth.

7. In a wave-power-storing apparatus, the combination, with a pier and a rotatable and vertically-movable sleeve or collar on said

pier, of a float hinged to said sleeve, a support fixed to said sleeve, and a series of air-compressing pumps mounted in said support, and in multiple with each other, whereby one pump forces air into the next pump, said pumps having piston-rods operatively connected with said float, substantially as and for the purposes set forth.

8. In a wave-power-storing apparatus, the combination, with a pier, of a float hinged to said pier, a support on said pier, an air-compressing pump mounted in said support, said pump having its piston operatively connected with said float, and mechanism for raising and lowering said support and pump, and the fulcrumal point of said float, substantially as and for the purposes set forth.

9. In a wave-power-storing apparatus, the combination, with a pier, of a float hinged to said pier, a support on said pier, a series of air-compressing pumps mounted in said support, and in multiple with each other, whereby one pump forces air into the next pump, said pumps having piston-rods operatively connected with said float, and mechanism for raising and lowering said support and pumps and the fulcrumal point of said float, substantially as and for the purposes set forth.

10. In a wave-power-storing apparatus, the combination, with a pier, of a float hinged to said pier, and having a lateral swimming motion, a laterally-movable support on said pier, an air-compressing pump mounted in said support, said pump having its piston operatively connected with said float, and mechanism for raising and lowering said support and pumps, and the fulcrumal point of said float, substantially as and for the purposes set forth.

11. In a wave-power-storing apparatus, the combination, with a pier, of a float hinged to said pier, and having a lateral swimming motion, a laterally-movable support on said pier, a series of air-compressing pumps mounted in said support, and in multiple with each other, whereby one pump forces air into the next pump, said pumps having piston-rods operatively connected with said float, and mechanism for raising and lowering said support and pumps, and the fulcrumal point of said float, substantially as and for the purposes set forth.

12. In a wave-power-storing apparatus, the combination, with a pier, and a rotatable and vertically-movable sleeve or collar on said pier, of a float hinged to said sleeve, a support fixed to said sleeve, an air-compressing pump mounted in said support, said pump having its piston-rod operatively connected with said float, and mechanism for operating said sleeve or collar and raising or lowering said support and pumps and the fulcrumal point of said float, substantially as and for the purposes set forth.

13. In a wave-power-storing apparatus, the combination, with a pier, and a rotatable and vertically-movable sleeve or collar on said

5 pier, of a float hinged to said sleeve, a support fixed to said sleeve, a series of air-compressing pumps mounted in said support, and in multiple with each other, whereby one
 10 pump forces air into the next pump, said pumps having piston-rods operatively connected with said float, and mechanism for operating said sleeve or collar, and raising or lowering said support and pumps, and the
 15 fulcrumal point of said float, substantially as and for the purposes set forth.

14. In a wave-power-storing apparatus, the combination, with a pier, a collar a^b on said pier, a ball-bearing connected with said collar, a sleeve rotatably arranged on said ball-bearing and an apron on said sleeve for protecting said bearing, of a float hinged to said sleeve, a support fixed to said sleeve, and an
 20 air-compressing pump mounted in said support, said pump having its piston-rod operatively connected with said float, substantially as and for the purposes set forth.

15. In a wave-power-storing apparatus, the combination, with a pier, a collar a^b on said pier, a ball-bearing connected with said collar, a sleeve rotatably arranged on said ball-bearing, and an apron on said sleeve for protecting said bearing, of a float hinged to said sleeve, a support fixed to said sleeve, and a
 25 series of air-compressing pumps mounted in said support, and in multiple with each other, whereby one pump forces air into the next pump, and said pumps having piston-rods operatively connected with said float, substantially
 30 as and for the purposes set forth.

16. In a wave-power-storing apparatus, the combination, with a pier, a rotatably-arranged and screw-threaded sleeve a^b on said pier, a sleeve c having an internal screw-thread fitted
 35 and adapted to travel on the threaded portion of said sleeve a^b , and a sleeve c^t rotatably arranged on said sleeve c , of a float hinged to said sleeve c^t , a support fixed to said sleeve c^t , and an air-compressing pump mounted in said
 40 support, said pump having its piston operatively connected with said float, substantially as and for the purposes set forth.

17. In a wave-power-storing apparatus, the combination, with a pier, a rotatably-arranged and screw-threaded sleeve a^b on said pier, a sleeve c having an internal screw-thread fitted and adapted to travel on the threaded portion
 45 of said sleeve a^b , and a sleeve c^t rotatably arranged on said sleeve c , of a float hinged to said sleeve c^t , a support fixed to said sleeve c^t , and a series of air-compressing pumps mounted in said support, and in multiple with
 50 each other, whereby one pump forces air into the next pump, and said pumps having piston-rods operatively connected with said float, substantially as and for the purposes set forth.

18. In a wave-power-storing apparatus, the combination, with a pier, a rotatably-arranged and screw-threaded sleeve a^b on said pier, a sleeve c having an internal screw-thread fitted and adapted to travel on the threaded portion
 55 of said sleeve a^b , a bearing portion c^t on

said sleeve c , a sleeve c^t rotatably arranged on said sleeve c , ball-bearings between the said respective sleeves, and an apron connected
 60 with said sleeve c^t for protecting the bearings, of a float hinged to said sleeve c^t , a support fixed to said sleeve c^t , and an air-compressing pump mounted in said support, said
 65 pump having its piston operatively connected with said float, substantially as and for the purposes set forth.

19. In a wave-power-storing apparatus, the combination, with a pier, a rotatably-arranged and screw-threaded sleeve a^b on said pier, a sleeve c having an internal screw-thread fitted and adapted to travel on the threaded portion
 70 of said sleeve a^b , a bearing portion c^t on said sleeve c , a sleeve c^t rotatably arranged on said sleeve c , ball-bearings between the said respective sleeves, and an apron connected
 75 with said sleeve c^t for protecting the bearing, of a float hinged to said sleeve c^t , a support fixed to said sleeve c^t , and a series of air-compressing pumps mounted in said support, and in multiple with each other, whereby
 80 one pump forces air into the next pump, and said pumps having piston-rods operatively connected with said float, substantially as and for the purposes set forth.

20. In a wave-power-storing apparatus, the combination, with a pier, a rotatable and vertically-traveling sleeve on said pier, a float connected with said sleeve, and a pump or
 85 pumps operatively connected with said float, of a gear mechanism connected with a gear on said sleeve, for raising or lowering said pump or pumps and the fulcrumal point of the float, and means for operating said gear
 90 mechanism, substantially as and for the purposes set forth.

21. In a wave-power-storing apparatus, the combination, with a pier, a rotatable and vertically-traveling sleeve on said pier, a float connected with said sleeve, and a pump or
 95 pumps operatively connected with said float, of a gear mechanism adapted to actuate said sleeve, for raising and lowering said pump or pumps and the fulcrumal point of the float, comprising an air-engine, a clutch and intermediate
 100 shafting and gearing for connecting said engine and clutch with a gear on said sleeve, a pipe for conveying compressed air to said engine, a valve in said pipe, and an electric regulator or controlling device, for
 105 properly operating said clutch and said valve, substantially as and for the purposes set forth.

22. In a wave-power-storing apparatus, the combination, with a hollow pier having an opening or openings for the admission of water
 110 into the same, of a rotatable and vertically-traveling sleeve on said pier, a float hinged to said sleeve, and a pump or pumps operatively connected with said float, of a mechanism adapted to actuate said sleeve, for
 115 raising and lowering said pump and the fulcrumal point of the float, a tide-float in said hollow pier, and means connected with said tide-float and said sleeve-actuating mechanism

ism for controlling the latter, substantially as and for the purposes set forth.

23. In a wave-power-storing apparatus, the combination, with a hollow pier having an opening or openings for the admission of water into the same, of a rotatable and vertically-traveling sleeve on said pier, a float hinged to said sleeve, and a pump or pumps operatively connected with said float, of a mechanism adapted to actuate said sleeve, for raising and lowering said pump or pumps and the fulcrumal point of the float, comprising an air-engine, a clutch and intermediate shafting and gearing for connecting said engine and clutch with a gear on said sleeve, a pipe for conveying compressed air to said engine, a valve in said pipe, an electric regulator or controlling device for properly operating said clutch and said valve, a tide-float in said hollow pier, and means connected with said tide-float and said electric regulator or controlling device for controlling the same, and actuating said clutch and opening or closing said valve at the proper times, substantially as and for the purposes set forth.

24. The combination, with a series of piers a' , of a rotatable and vertically-traveling sleeve on each pier, a float hinged to each sleeve and a pump or pumps operatively connected with each float, a mechanism connected with and operating said sleeves simultaneously, and means for operating said sleeve-operating mechanism, substantially as and for the purposes set forth.

25. The combination, with a series of piers a' , a rotatable and vertically-traveling sleeve on each pier, and a gear on each sleeve, of a float hinged to each sleeve, and a pump or pumps operatively connected with each float, a cross-shaft having worms in operative mesh with the gears on said sleeves, and means connected with said cross-shaft for actuating the same, substantially as and for the purposes set forth.

26. In a wave-power-storing apparatus, the combination, with a pier, of a float hinged to said pier, a pair of supporting-arms d secured on said pier, bolts connecting said arms, and an air-compressing pump pivotally connected with one of said bolts, said pump having its piston operatively connected with said float, substantially as and for the purposes set forth.

27. In a wave-power-storing apparatus, the combination, with a pier, of a float hinged to said pier, a pair of supporting-arms d secured on said pier, bolts as d^6 and d^7 , connecting said arms, and air-compressing cylinders pivotally connected with said bolts, and a means of communication from one pump to the other, whereby one pump forces air into the next pump, and said pumps having piston-rods pivotally connected with said float, substantially as and for the purposes set forth.

28. In a wave-power-storing apparatus, the combination, with a pier, of a float hinged to said pier, a support on said pier, and a pump mounted in said support and having its piston-rod operatively connected with said float, an air-inlet pipe connected with said pump, having a hood h^2 and shield h^3 , substantially as and for the purposes set forth.

29. In a wave-power-storing apparatus, the combination, with a pier, of a float hinged to said pier, and having a lateral swimming motion, a laterally-moving support on said pier, a pump or pumps mounted in said support, and a rope or flexible connection, connected with said float to limit its lateral motion, substantially as and for the purposes set forth.

30. In a wave-power-storing apparatus, the combination, with a pier and connecting bridge or platform, of a float hinged to said pier, and having a lateral swimming motion, a laterally-moving support on said pier, a pump or pumps mounted in said support, a windlass on said bridge or platform, and a rope or flexible connection connected with said float to limit its lateral motion, substantially as and for the purposes set forth.

31. In a wave-power-storing apparatus, the combination with a pier, a float hinged thereto, a support on said pier, and an air-compressing pump having eyes f^{10} and f^{11} , reciprocatory-moving rods f^{12} in said eyes, a cross-head f^{13} , and a bearing f^{14} therein, through which the piston-rod of said pump works, substantially as and for the purposes set forth.

In testimony that I claim the invention set forth above I have hereunto set my hand this 28th day of January, 1898.

SAMUEL H. JONES.

Witnesses:

FRED. CROW,
FREDK. C. FRAENTZEL.